

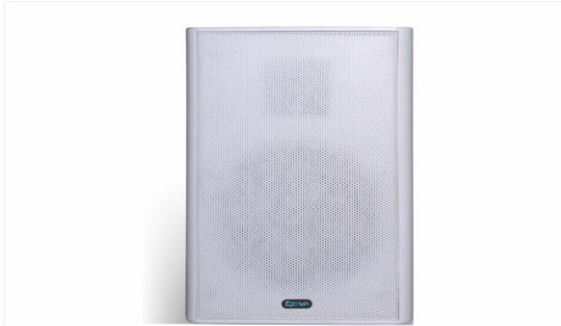

NT - 509 FS Fashion Speaker



NT-509FS

- **Material:** HIPS
- **Frequency Response:** 120Hz-20KHz
- **Drive & Sensitivity:** L:5"/H:2" & 90 dB
- **Line Voltage:** 70V-100V
- **Power:** 20 W or 4 ohm
- **Dimension (mm):** 275x185x40
- **Net weight:** 1 KG

Fashion speakers, also known as designer speakers, combine high-quality audio with stylish design, making them ideal for modern living spaces.

Concept Sketch

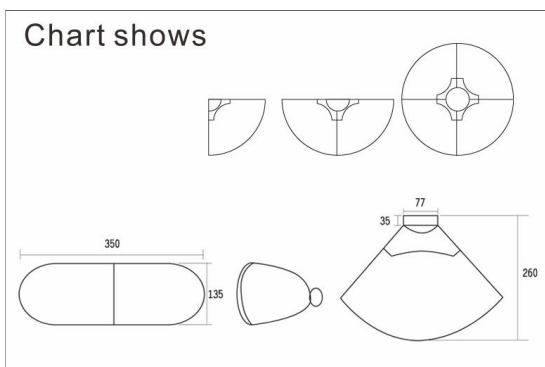

Secondary aspects

Fashion speakers feature multi-room audio for synchronized playback. They can be integrated seamlessly with voice assistants such as Alexa or Google Assistant, allowing for convenient voice control.

Fashion speakers

also known as designer speakers, blend high-quality audio with stylish design, making them ideal for modern living spaces. Crafted from premium materials like wood, metal, and glass, these speakers are visually striking and acoustically advanced. Most models can be wall-mounted, offering a space-saving solution while maintaining an elegant look. They are built using HIPS (High Impact Polystyrene) materials to ensure durability and superior sound quality. The attractive cabinet design improves sound directivity, enhancing the listening experience.

Additionally

these speakers are designed for easy and prompt installation, with flexible assembly options and a concise, trendy outline that complements various interiors. Their customizable sound profiles, smart home integration, and adaptive sound technologies further enhance their functionality, making them a sophisticated addition to any home or commercial space.